

<b>DTC</b>	<b>P0100/31</b>	<b>Mass or Volume Air Flow Circuit</b>
------------	-----------------	--

<b>DTC</b>	<b>P0102/31</b>	<b>Mass or Volume Air Flow Circuit Low Input</b>
------------	-----------------	--

<b>DTC</b>	<b>P0103/31</b>	<b>Mass or Volume Air Flow Circuit High Input</b>
------------	-----------------	---

## CIRCUIT DESCRIPTION

The Mass Air Flow (MAF) meter measures the amount of air flowing through the throttle valve. The engine control ECU uses this information to determine the fuel injection time and provide a proper air fuel ratio. Inside the MAF meter, there is a heated platinum wire exposed to the flow of intake air.

By applying a specific current to the wire, the engine control ECU heats this wire to a given temperature. The flow of incoming air cools the wire and an internal thermistor, affecting their resistance. To maintain a constant current value, the engine control ECU varies the voltage applied to these components in the MAF meter. The voltage level is proportional to the airflow through the sensor. The engine control ECU interprets this voltage as the intake air amount.

The circuit is constructed so that the platinum hot wire and temperature sensor provide a bridge circuit, with the power transistor controlled so that the potential of A and B remains equal to maintain the set temperature.

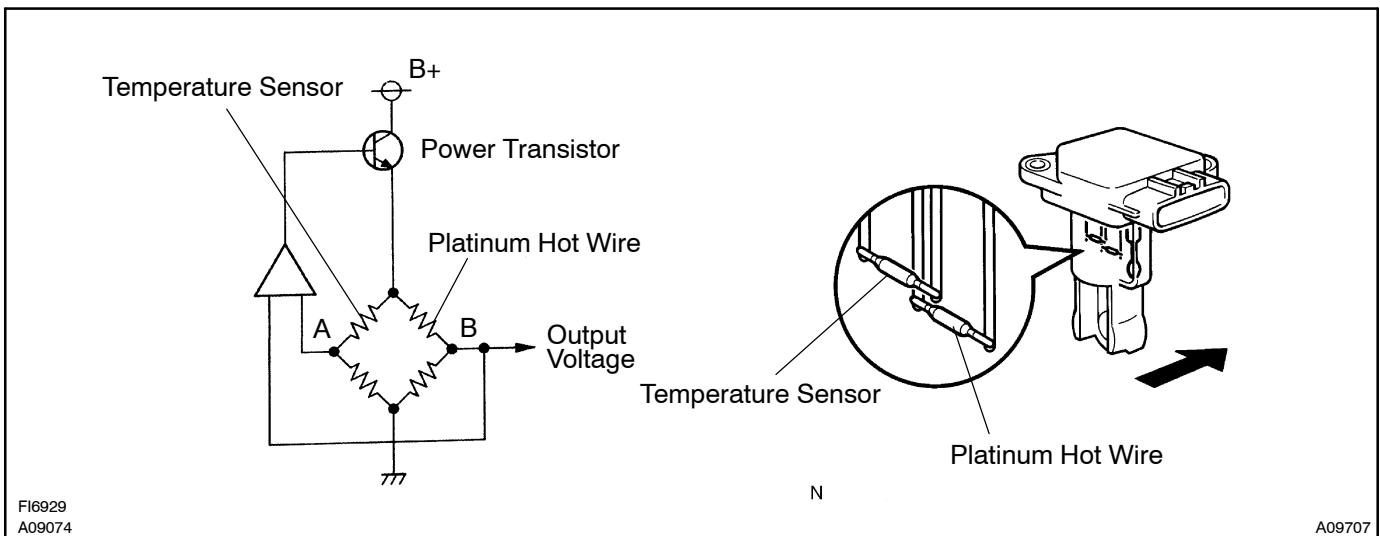

DTC No.	DTC Detection Condition	Trouble Area
P0100/31	Open or short in mass air flow meter circuit for more than 3 sec. (MAF sensor voltage is less than 0.2 V or more than 4.9 V) (1 trip detection logic)	<ul style="list-style-type: none"> <li>• Open or short in mass air flow meter circuit</li> <li>• Mass air flow meter</li> <li>• Engine control ECU</li> </ul>
P0102/31	Open or short in mass air flow meter circuit for more than 3 sec. (MAF sensor voltage is less than 0.2 V) (1 trip detection logic)	
P0103/31	Open in mass air flow meter circuit for more than 3 sec. (EVG circuit) Short in mass air flow meter circuit for more than 3 sec. (+B circuit) (MAF sensor voltage is more than 4.9 V) (1 trip detection logic)	

**HINT:**

After confirming DTC P0100/31, P0102/31 or P0103/31, use the hand-held tester to confirm the MAF ratio from the ALL menu (to reach the ALL menu: DIAGNOSIS / OBD/MOBD / DATA LIST / ALL).

Mass Air Flow Value (gm/sec.)	Malfunction
Approx. 0.0	<ul style="list-style-type: none"> <li>• Mass air flow meter power source circuit open</li> <li>• VG circuit open or short</li> </ul>
271.0 or more	<ul style="list-style-type: none"> <li>• EVG circuit open</li> </ul>

**MONITOR DESCRIPTION**

If there is a defect in the MAF (Mass Air Flow) meter or an open or short circuit, the voltage level will deviate outside the normal operating range. The engine control ECU interprets this deviation as a defect in the MAF meter and sets a DTC.

Example:

When the MAF meter voltage output is less than 0.2 V, or more than 4.9 V, and if either the condition continues for more than 3 sec.

This monitor runs for 3 seconds (the first 3 of engine idle) after the engine started.

**WIRING DIAGRAM**

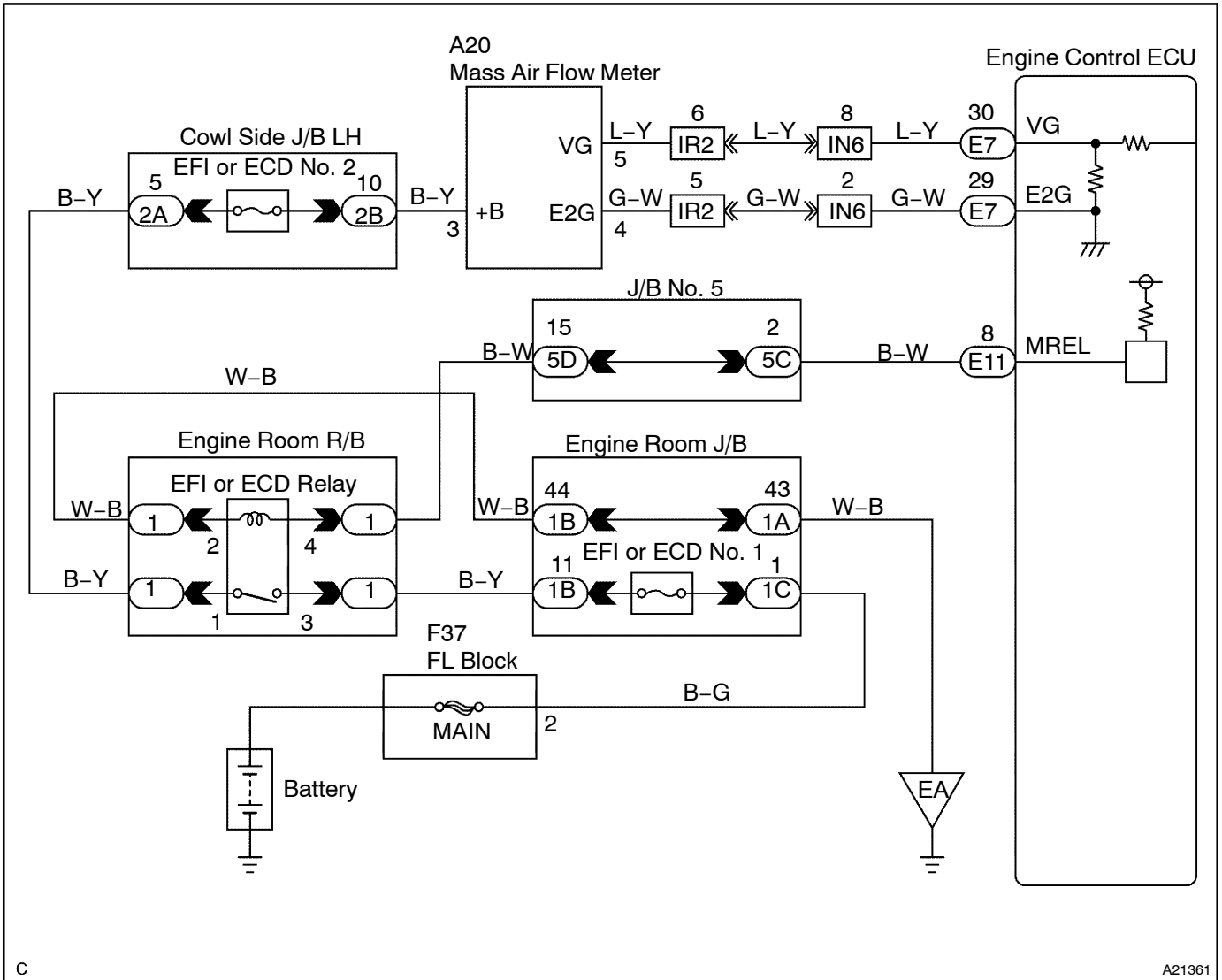

C

A21361

## INSPECTION PROCEDURE

### HINT:

Read freeze frame data using the hand-held tester. Freeze frame data records the engine conditions when a malfunction is detected. When troubleshooting, freeze frame data can help determine if the vehicle was running or stopped, if the engine was warmed up or not, if the air-fuel ratio was lean or rich, and other data from the time the malfunction occurred.

**1** Connect hand-held tester, and read value of mass air flow rate.

### PREPARATION:

- Connect the hand-held tester to the DLC3.
- Turn the ignition switch ON and push the hand-held tester main switch ON.
- Start the engine.
- When using hand-held tester, enter the following menu: DIAGNOSIS / OBD/MOBD / DATA LIST / ALL / MAF.

### CHECK:

Read the mass air flow rate on the hand-held tester.

### RESULT:

Air Flow Rate (gm/s)	Proceed to
0.0	A
271.0 or more	B
Between 1 and 270.0 (*1)	C

\*1: The value must be changed when the throttle valve is opened or closed.

**B**

Go to step 6.

**C**

Check for intermittent problems  
(See page DI-3)

**A**

**2 Check voltage of air flow meter power source.**

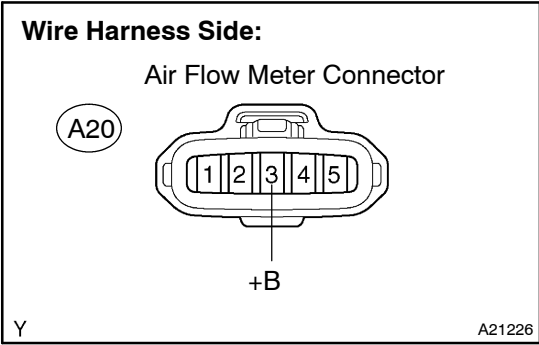

**PREPARATION:**

- (a) Disconnect the A20 air flow meter connector.
- (b) Turn the ignition switch ON.

**CHECK:**

Measure voltage between terminal of the mass air flow meter connector and body ground.

**OK:**

Tester Connection	Specified Condition
+B (A20-3) - Body ground	9 to 14 V

**NG** → **Go to step 5.**

**OK**

**3 Check voltage between terminal VG of engine control ECU connector and body ground.**

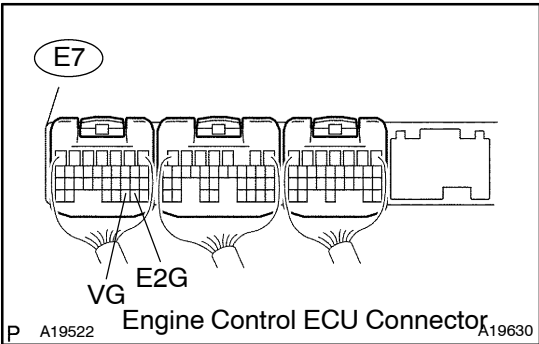

**PREPARATION:**

Start the engine.

**CHECK:**

Measure the voltage between the specified terminal of the E7 engine control ECU connector.

**HINT:**

The shift position should be P or N and the A/C switch should be turned OFF.

**OK:**

Tester Connection	Condition	Specified Condition
VG (E7-30) - E2G (E7-29)	Engine is idling	0.5 to 3.0 V

**OK** → **Replace engine control ECU (See Pub. No. RM630E, page FI-74).**

**NG**

**4 Check for open and short in harness and connector between air flow meter and engine control ECU.**

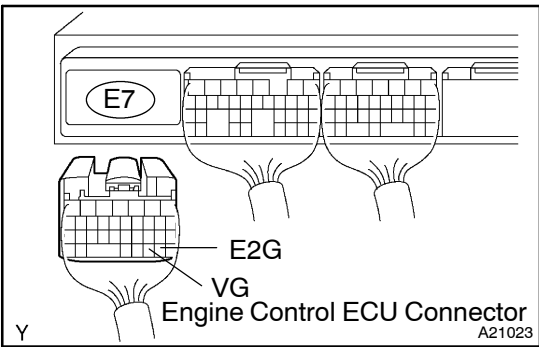
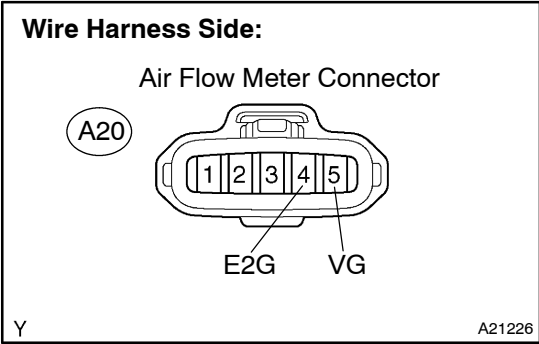

**PREPARATION:**

- (a) Disconnect the A20 air flow meter connector.
- (b) Disconnect the E7 engine control ECU connector.

**CHECK:**

Check the resistance between the wire harness side connectors.

**OK:**

Tester Connection	Specified Condition
VG (A20-5) - VG (E7-30)	Below 1 Ω
E2G (A20-4) - E2G (E7-29)	Below 1 Ω
VG (A20-5) or VG (E7-30) - Body ground	10 kΩ or higher

**OK**

**Replace air flow meter.**

**NG** **Repair or replace harness or connector.**

**5 Check for open and short in harness and connector between air flow meter and EFI or ECD relay.**

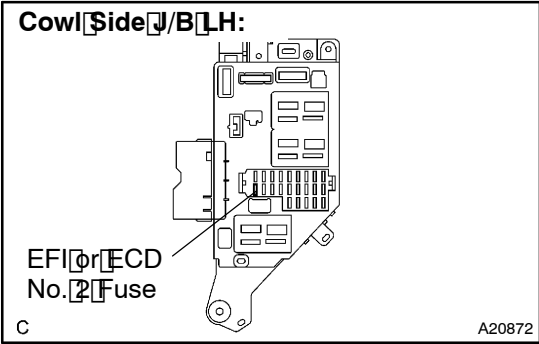

**Check EFI or ECD No. 2 fuse:**

**PREPARATION:**

Remove the EFI or ECD No. 2 fuse from the cowl side J/B LH.

**CHECK:**

Check for continuity in the EFI or ECD No. 2 fuse.

**OK:**

**Continuity**

**Check harness and connector:**

**PREPARATION:**

(a) Install the EFI or ECD No. 2 fuse.

(b) Disconnect the A20 air flow meter connector.

(c) Remove the EFI or ECD relay from the engine room R/B.

**CHECK:**

Check the resistance between the wire harness side connectors.

**OK:**

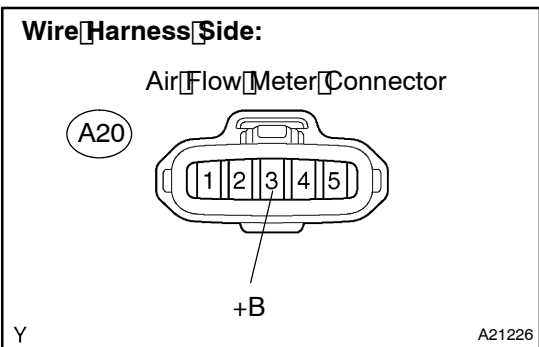

Tester Connection	Specified Condition
+B (A20-3) - Engine Room J/B (EFI or ECD relay terminal 1)	Below 1 Ω
+B (A20-3) or Engine Room J/B (EFI or ECD relay terminal 1) - Body Ground	10 kΩ or higher

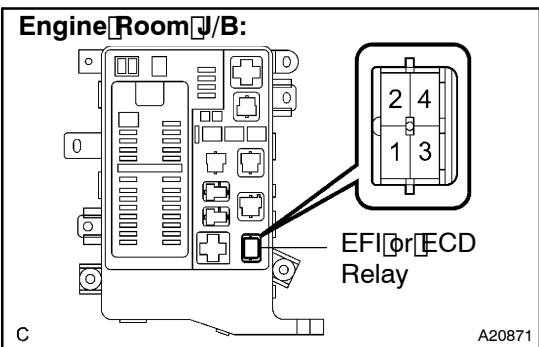

**NG** Repair or replace harness or connector.

**OK**

**Check engine control ECU power source circuit (See page DI-237).**

**6 Check continuity between terminal E2G of engine control ECU connector and body ground.**

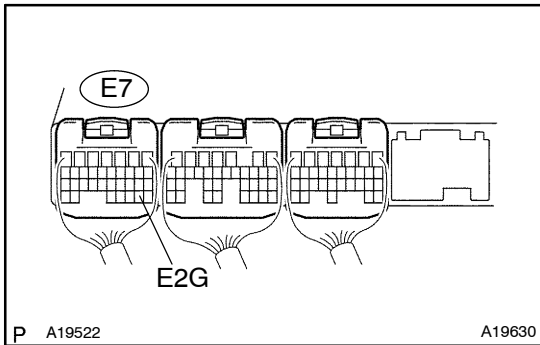

**CHECK:**

Check the resistance between terminal of the E7 engine control ECU connector and body ground.

**OK:**

Tester Connection	Specified Condition
E2G (E7-29) - Body ground	Below 1 $\Omega$

**NG**

**Go to step 8.**

**OK**

**7 Check for open in harness and connector between air flow meter and engine control ECU.**

**Wire Harness Side:**

Air Flow Meter Connector

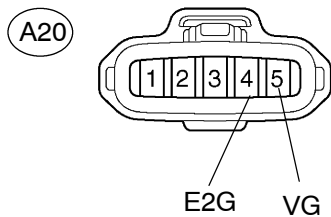

**PREPARATION:**

- Disconnect the A20 air flow meter connector.
- Disconnect the E7 engine control ECU connector.

**CHECK:**

Check the resistance between the wire harness side connectors.

**OK:**

Tester Connection	Specified Condition
VG (A20-5) - VG (E7-30)	Below 1 $\Omega$
E2G (A20-4) - E2G (E7-29)	Below 1 $\Omega$
VG (A20-5) or VG (E7-30) - Body ground	10 k $\Omega$ or higher
E2G (A20-4) or E2G (E7-29) - Body ground	10 k $\Omega$ or higher

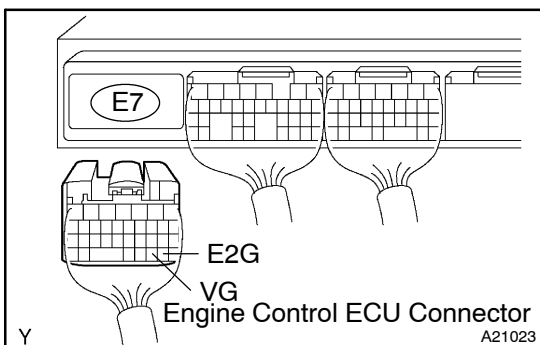

**NG**

**Repair or replace harness or connector.**

**OK**

**Replace mass air flow meter.**

8 Check for open in harness and connector between terminal E1 of engine control ECU and body ground (See page IN-20).

NG

Repair or replace harness or connector.

OK

Replace engine control ECU (See Pub. No. RM630E, page FI-74).